

ICC Evaluation Service, Inc.
www.icc-es.org

Business/Regional Office ■ 5360 Workman Mill Road, Whittier, California 90601 ■ (562) 699-0543
Regional Office ■ 900 Montclair Road, Suite A, Birmingham, Alabama 35213 ■ (205) 599-9800
Regional Office ■ 4051 West Flossmoor Road, Country Club Hills, Illinois 60478 ■ (708) 799-2305

DIVISION: 03—CONCRETE
Section: 03370—Specially Placed Concrete

DIVISION: 07—THERMAL AND MOISTURE PROTECTION
Section: 07430—Composite Panels

REPORT HOLDER:

STRATA INTERNATIONAL GROUP, INC. (SIG)
1626 SOUTH 51ST AVENUE
PHOENIX, ARIZONA 85043
(602) 547-8008
www.sabs.info
nsaebi@strataus.com

EVALUATION SUBJECT:

SAEBI ALTERNATIVE BUILDING SYSTEM (SABS™)

1.0 EVALUATION SCOPE

Compliance with the following codes:

- 2003 *International Building Code*® (IBC)
- 2003 *International Residential Code*® (IRC)
- Legacy Codes (see Section 8.0)

Properties evaluated:

- Structural
- Fire exposure
- Durability
- Weather protection

2.0 USES

The Saebi Alternative Building System (SABS™) functions as structural walls, floors, and roofs in buildings of Type V-B (combustible) construction. SABS™ may be directly exposed to the interior and exterior without protective coverings, and is a Class A roof covering assembly when constructed in accordance with this report. Systems that include floors above grade are limited to Group R occupancies. SABS™ may also be used where an engineered design is submitted in accordance with Section R301.1.3 of the IRC.

3.0 DESCRIPTION

3.1 General:

The SABS™ consists of preformed expanded polystyrene (EPS) foam plastic elements joined together with adhesives and covered with structural coatings on all faces, forming “sandwich” type composite structural elements. Figure 1 illustrates a typical rectangular panel and Figure 2 illustrates a typical I-shaped beam. When the EPS foam plastic core components of the structure are coated with the structural coatings, the composite assembly becomes a completely monolithic “box-frame” structure.

3.2 Materials:

3.2.1 EPS: The EPS is either Type I or Type II in accordance with ASTM C 578. Nominal EPS density is either 1.0 pcf or 1.5 pcf (16 kg/m³ to 24 kg/m³). Molded into various configurations such as rectangular, curved, or I shapes, the EPS thickness ranges from 2 inches to 16 inches (51 mm to 406 mm), depending on end use and design considerations. Surface burning characteristics are a flame-spread index of 25 or less and a smoke-developed index of 450 or less when tested in accordance with ASTM E 84 at a 4-inch (102 mm) thickness. The EPS is supplied by sources described in the approved quality documentation.

3.2.2 SABS™ Structural Coatings: The SABS™ structural coatings are composite materials consisting of Type III portland cement, silica sand, alkali-resistant glass fibers, water, and proprietary admixtures. Flexural strength and modulus of elasticity must be determined by tests in accordance with ASTM C 947, and compressive strength must be determined by tests in accordance with ASTM C 109. The thicknesses of these structural coatings range from 1/4 inch to 2 inches (6.4 to 51 mm), depending on the required loads imposed on the structural components as described in the structural design documentation. The structural coating is a Class A interior finish with a flame-spread index of 25 or less and a smoke-developed index of 450 or less when tested in accordance with ASTM E 84 at a 1/4-inch (6.4 mm) thickness. The structural coating complies with Section 2603.4 of the IBC as a thermal barrier when applied to foam plastic roof components up to 16 inches (406 mm) thick or wall elements up to 8 inches (203 mm) thick.

3.2.2.1 Cement: The cement must be Type III portland cement, complying with ASTM C 150. Packaged in 94 1/2-pound (42.865 kg) bags, the cement must be stacked on pallets or similar platforms to avoid contact with moisture and to permit proper air circulation. Bags must be stored clear of all areas where condensation may occur. Cement must not be stacked in piles higher than 14 bags for a storage period of more than 60 days. For longer storage periods, the stack must not exceed seven bags. Cement stored for more than 90 days must be inspected, and any cement bags that have developed lumps that cannot be reduced by light finger pressure must not be used.

3.2.2.2 Sand: The sand must be silica sand, complying with ASTM C 33. Packaged in 100-pound (45.359 kg) bags, it has an indefinite shelf life.

3.2.2.3 SABS™ Copolymer: The SABS™ Copolymer admixture is an aqueous acrylic thermoplastic copolymer dispersion. Packaged in 12-pound (5.443 kg) clear plastic bags, the material has a shelf life of one year when stored in a dry location, and must be protected from direct sunlight, high heat sources, and freezing.

3.2.2.4 Fibers: The fibers are alkali-resistant, continuous-filament, chopped glass strands, complying with Appendix K of the PCI Recommended Practice for Glass Fiber Reinforced Concrete Panels, and packaged in three-pound (1.36 kg) bags.

3.2.2.5 Additional Admixtures: Additional concrete admixtures, such as SABS™ Superplasticizer and SABS™ Retarder, are normally used to enhance the workability and setting time of the mixture. These materials have a shelf life of three years when stored at ambient temperatures in a dry location.

3.2.3 Adhesive Used to Adhere EPS Segments: The EPS segments used to create foundation, stem wall, wall, floor, and roof elements are bonded together, prior to structural coating with the SABS™ proprietary structural coating, using single- or two-part foam plastic adhesives. Only adhesives permitted by SIG and described in the SABS™ Construction Manual may be used.

4.0 DESIGN AND INSTALLATION

4.1 General:

All SABS™ structures must be designed and either prefabricated or constructed on-site in accordance with Strata International Group's approved manuals as listed below, the IBC or IRC, and this report:

- SABS™ Construction Manual, Version 9.1, dated July 2007.
- SABS™ Quality Control Manual, Version QCM-1.002, dated February 2007.

Each of the above-referenced documents must be provided to the installer upon completion of the required training and certification course provided by SIG. A copy of these manuals must accompany the project information documents for each structure.

All construction utilizing SABS™, including installation of components or construction of SABS™ structures, must comply with the referenced SABS™ manuals, the IBC or IRC, and this report. The EPS rectangular or curved components may be fabricated and pre-coated in an off-site or on-site location, then erected, coated and finished in compliance with the project plans and specifications and the SABS™ Construction Manual. The resulting assemblies must be inspected by the building official, the special inspector, and Strata International Group in accordance with SABS™ Quality Control Manual. Complete copies of the published SABS™ Construction Manual and SABS™ Quality Control Manual and this report must be made available at all times on the jobsite during installation of SABS™.

4.2 Structural Design:

4.2.1 General: To ensure structural integrity, the SABS™ must be subjected to a structural analysis, prior to construction, conducted by registered design professionals trained and certified by SIG. The structural analysis must be used to determine structural capacities for all portions of the SABS™ structure. As the SABS™ structure is a continuous structural system, the finite element method of analysis (FEA) can be used to determine the structural resistance.

4.2.2 Design Criteria: The minimum structural design criteria for SABS™ structures must be in compliance with the IBC and ASCE/SEI 7.

Floors are limited to a maximum allowable uniform load of 40 psf (1915 Pa). Resistance to concentrated loads as set forth in Table 1607.1 of the IBC is outside the scope of this report.

Wind resistance must be limited to 170 mph (76 m/s) maximum basic wind speeds.

The seismic coefficients, factors, and height limits for seismic force resisting systems must not exceed the following values:

$$R: 4$$

$$\Omega_o: 3^{1/2}$$

$$C_d: 4$$

The permitted Seismic Design Categories are A, B, C, D, E, or F. The building height is limited to a maximum of 40 feet (12 192 mm). In Seismic Design Category D, E, or F, the fundamental period, T , must be computed precisely in accordance with Section 9.5.5.3 of ASCE/SEI 7. Use of T_a is not permitted. In Seismic Design Category D, E, or F, SABS™ must comply as regular structures with $T < 3.5 T_s$ in Table 9.5.2.5.1 of ASCE/SEI 7.

The following parameters must be the controlling factors in the design of SABS™ structures:

1. Flexural strength: Allowable design flexural stresses must be no greater than one-third of the values determined in accordance with ASTM C 947 for the structural coating, and must not exceed 667 psi (4.596 MPa).
2. Compressive strength: Allowable design compressive stresses must be no greater than one-third of the values determined in accordance with ASTM C 109 for the structural coating, and must not exceed 2,667 psi (18.367 MPa).
3. Modulus of elasticity for the structural coating used in design must be a maximum of 1,000,000 psi (6,895 MPa).
4. Modulus of elasticity of the EPS foam plastic used in design must be a maximum of 320 psi (2.205 MPa).
5. Strain: The design strain limit for SABS™ structural coating must be a maximum of 0.00067 in/in (mm/mm).
6. Deflection: The span/deflection ratio of all SABS™ structural components in flexure must be maximum of 1/480 for combinations of dead and live loads ($D + L$). For other load combinations, limitations in the IBC must be observed.

Expansion joints may be required as specified by the structural design, subject to the approval of the building official. The symmetrical joints are constructed by cutting $1/4$ -inch-wide (6.4 mm) grooves in the cured structural coating by means of a rotary diamond saw, and covering the space with an approved weather-resistant material. The joint must parallel the spanning direction of the wall, floor, or roof element, without intersecting the loading direction of load bearing walls.

4.3 Installation:

4.3.1 General: All applicators must be trained and certified by SIG. A list of all certified applicators must be made available at all SABS™ jobsite locations. The applicators must complete an annual update of their training, which includes retesting, and be retested to maintain their certification by SIG. SABS™ structures must be constructed or installed in two primary classes: (1) custom and (2) prefabricated or high-volume production structures. Subassemblies of SABS™ components before erection may be prefabricated by Strata International Group, or produced at the jobsite location. In either case, the structural design and construction quality control procedures must remain the same. In both classes, the thicknesses of the EPS foam plastic core and structural coating on both sides of the core must be predetermined by the structural analysis performed by a trained Strata International Group registered design professional.

The adhesive described in Section 3.2.3 must be used to connect EPS foam plastic sections to each other prior to the structural coating application. The structural coating provides the continuity for the entire SABS™ system. Precoated EPS sections must be recoated after assembly and erection to provide structural coating continuity at the joints as specified by the structural design.

The structural coating is spray-applied to EPS surfaces that are clean and free of loose particles and excess water.

Interior and exterior finishes and coverings may be installed in accordance with the IBC or IRC. Use of mechanical fastenings is outside the scope of this report.

The foam plastic locations relative to termite infestation potential must comply with IRC Sections R314.5 and R320.4.

Typical details are provided in Figure 3.

4.3.2 Wall Elements: The SABS™ wall elements include both exterior and interior walls. These walls must use the standard configuration as shown in Strata International Group's approved plans and in accordance with the SABS™ Construction Manual. The walls must be joined to the foundation, stem wall, floor, wall, and/or roof elements with the SABS™ structural coating in the thickness determined by the structural design.

When EPS wall components are adhered to each other or to door or window frames, care must be taken to avoid an excessive deposit of the adhesive, to prevent misalignment of components due to excessive adhesive expansion. Care also must be taken to avoid covering of exposed EPS surfaces with adhesives, to allow for proper bonding to the EPS.

Once the EPS wall components are erected, the SABS™ structural coating must be applied to the prescribed thickness by use of screeds or gauge-equipped trowels.

4.3.3 Floor Elements: Once the wall elements are installed, the floor elements must be placed on top of the walls and preconnected at the EPS joints with the EPS adhesive before application of structural coating for final joint connection. The SABS™ floor elements must be flat elements consisting of rectangular block or I-shaped beams in flat configurations.

The floor elements can also be partially precoated on both sides, installed, and then coated with a second layer of structural coating when all the floor elements are placed in position.

Standard floor coverings must be applied over SABS™ components in accordance with the IBC, IRC, or a current ICC-ES report, when approved by the building official and SIG. Floor finish materials must comply with Section 804 of the IBC.

4.3.4 Roof Elements: Once the wall elements are installed, the roof elements must be placed on top of the walls and preconnected at the EPS joints with the EPS adhesive before application of structural coating for final joint connection. Several types of SABS™ roof elements may be used; these include curved or flat elements consisting of rectangular block or I-shaped beams in curved or flat configurations.

The flat elements must be generally used for sloped roof applications. The roof elements can be partially precoated on both sides, installed, and then coated with a second layer of structural coating when the roof elements are all placed in position.

4.3.5 Roof Assembly Classification: SABS™ roof elements with a minimum 8-inch-thick (203 mm) EPS core component and a minimum of 1/4-inch-thick (6.4 mm) SABS™ structural coating on both faces comply as a Class A roof assembly when tested in accordance with ASTM E 108.

4.3.6 Installation of Windows and Doors: Guidelines for installing windows and doors are detailed in the SABS™ Construction Manual. Installation methods may vary according to the product being attached. The SABS™ elements must be designed to adequately support the window or door.

4.3.7 Electrical, Plumbing, and HVAC: Electrical, plumbing, heating, ventilation, and air-conditioning components must be installed in accordance with the IBC; the applicable electrical, plumbing or mechanical code; the SABS™ Construction Manual; and the approved plans.

4.4 Special Inspection:

4.4.1 General: Special inspection in accordance with Section 1704 of the IBC must be provided. The special inspector's duties must include:

- Verification of jobsite-prepared structural coating.
- Verification of size and location of structural elements.
- Verifying protection of construction during cold or hot weather.
- Verifying that EPS surfaces are clean and dry prior to structural coating application.
- Verifying that structural coating application techniques and thicknesses are in compliance with this report and construction document provisions.
- Verifying that specified curing temperature and techniques are maintained.
- Verifying preparation of structural coating test specimens.
- Verification of compliance with required inspection provisions of the construction documents and the approved submittals.

4.4.2 Test Specimens: Structural coating test coupons must be made for each SABS™ structure, in accordance with ASTM C 1228, ASTM C 947, and ASTM C 109.

Three full sets must be collected for testing. One set of sample coupons must consist of two test boards that can be cut into the required number of testing coupons. The first sample must be collected from a sample batch mixed and applied during the first day of application for each structure. One of these sample boards must be shipped to a testing laboratory that is approved by the building official. Two additional sets of samples must be collected from two additional batches of structural coating applied during construction of the walls and roof structures or as specially requested by the building official, registered design professional, or project quality control manager.

Each coupon must be marked with the date, the specimen number (1-6), and the initials of the special inspector. The shipping record must include the following information:

- Date
- Location of the structure
- SABS™ structure registration number
- The name of the SABS™ installer
- License number for the SABS™ installer, issued by SIG
- Names of installer's crew
- Name and signature of the special inspector

All additional samples must be kept at the headquarters of the SIG licensee in a secure area, together with a copy of the above information for a period of three years after completion

of each structure. The SIG-licensed builder must be responsible for producing these samples upon request by the building official, SIG, or a testing laboratory approved by the building official. The test results must comply with the specifications set forth by the structural design.

4.4.3 Thickness: The thickness of the structural coating at any location on the building may be verified by drilling a small hole through the structural coating until the drill hits the foam plastic. The thickness of the structural coating must be measured with a pin caliper.

5.0 CONDITIONS OF USE

The Saebi Alternative Building System (SABS™) described in this report complies with, or is a suitable alternative to what is specified in, those codes listed in Section 1.0 of this report, subject to the following conditions:

- 5.1 Installation complies with this report, the manufacturer's published construction and quality control manuals, and the applicable code. In the event of a conflict between the manufacturer's published documents and this report, this report governs.
- 5.2 The Strata Construction Manual, Version 9.1, dated July 2007, and the Strata Quality Control Manual, Version QCM-1.002, dated February 2007, must be submitted to the building official for approval and must be available at the jobsite at all times.
- 5.3 The structural design must comply with this report and the IBC, be accepted by SIG, and be approved by the building official.
- 5.4 Prior to installation, calculations and details demonstrating compliance with this report must be submitted to the building official for approval. The calculations and details must be prepared by a registered design professional where required by the statutes of the jurisdiction in which the project is to be constructed.
- 5.5 Structures containing SABS™ are limited to the IRC or to IBC Type V-B construction with a maximum of two stories.
- 5.6 Use of SABS™ structural coating as an interior finish is limited to a thickness of $\frac{1}{4}$ inch (6.4 mm), except when covered by approved finishes.
- 5.7 The SABS™ structural coating fibers and admixtures must be produced by Strata International Group, Phoenix, Arizona, under a quality control program with inspections by RADCO (AA-650).
- 5.8 Precoated SABS™ modules must be fabricated by Strata International Group, Phoenix, Arizona, under a quality control program with inspections by RADCO (AA-650).

6.0 EVIDENCE SUBMITTED

Data in accordance with the ICC-ES Acceptance Criteria for Sandwich Panels (AC04), dated May 2006; the ICC-ES Acceptance Criteria for Foam Plastic Insulation (AC12), dated June 2006; the ICC-ES Acceptance Criteria for Concrete and Concrete Masonry Wall Systems (AC15), dated June 2003; the ICC-ES Acceptance Criteria for Prefabricated Wood Shear Panels (AC130), dated February 2004; and the ICC-ES Acceptance Criteria for Composite Wall and Roof Panel Systems with an Expanded Polystyrene Core and Spray- or Trowel-applied Cementitious Facings (AC176), dated January 2001.

7.0 IDENTIFICATION

7.1 Fibers and Admixtures:

The containers are labeled with the SABS™ name, name of the product, product number, quality control number, manufacturer's name (Strata International Group) and address, manufacturing location, expiration date, evaluation report number (ESR-1638), and name of the inspection agency, (RADCO).

7.2 EPS:

The EPS components, either uncoated or precoated, are labeled with the SABS™ name, EPS vendor name, product number, production date, manufacturer's name (Strata International Group) and address, manufacturing location, evaluation report number (ESR-1638), and name of the inspection agency, (RADCO).

7.3 Precoated SABS™ Modules:

The precoated SABS™ modules must be identified with the SABS™ name, fabricator's name and address, registration number, completion date, manufacturer's name (Strata International Group) and address, evaluation report number (ESR-1638), and name of the inspection agency (RADCO).

7.4 Completed Structure:

The completed SABS™ structure bears a permanent tag, in a visible location, bearing the SABS™ name, structure registration number, completion date, manufacturer's name and address, builder name, builder license number, evaluation report number (ESR-1638), and name of the inspection agency (RADCO).

8.0 LEGACY CODES

In addition to the codes referenced in Section 1.0, the products in this report were evaluated for compliance with the requirements of the 1997 *Uniform Building Code*™ (UBC).

8.1 Uses:

The Saebi Alternative Building System (SABS™) functions as structural walls, floors, and roofs in buildings of Type V-N (combustible) construction. SABS™ may be directly exposed to the interior and exterior without protective coverings and is a Class A roof covering assembly when constructed in accordance with this report. Systems consisting of floors are limited to Group R occupancies.

8.2 Description:

See Section 3.0, except modify Section 3.2.1 as follows:

EPS: The EPS is either Type I or Type II in accordance with ASTM C 578. Nominal EPS density is either 1.0 pcf or 1.5 pcf (16 kg/m³ to 24 kg/m³). Molded into various configurations such as rectangular, curved, or I shapes, the EPS thickness ranges from 2 inches to 16 inches (51 mm to 406 mm), depending on end use. Surface burning characteristics are a flame-spread index of 25 or less and a smoke-developed index of 450 or less when tested in accordance with UBC Standard 8-1 at a 4-inch (102 mm) thickness. The EPS is supplied by sources described in the approved quality documentation.

Also modify Section 3.2.2 as follows:

SABS™ Structural Coatings: The SABS™ structural coatings are composite materials consisting of Type III portland cement complying with ASTM C 150, silica sand complying with ASTM C 33, alkali-resistant glass fibers, water, and proprietary admixtures. Flexural strength and modulus of elasticity verification must be determined by tests in accordance with ASTM C 947 and compressive strength must be determined by tests in accordance with ASTM C 109. The

thicknesses of these structural coatings range from $\frac{1}{4}$ inch to 2 inches (6.4 to 51 mm), depending on the required loads imposed on the structural components. The structural coating is a Class I interior finish with a flame spread index of 0-25 and a smoke-developed index of 0-450 when tested in accordance with UBC Standard 8-1 at a $\frac{1}{4}$ -inch (6.4 mm) thickness.

8.3 Design and Installation:

See Section 4.0, except as follows:

Replace Section 4.2 with the following:

To ensure structural integrity, the SABS™ must be subjected to a structural analysis, prior to construction, conducted by registered design professionals trained by Strata International Group. The structural analysis must be used to determine structural capacities for all portions of the SABS™ structure. As the SABS™ structure is a continuous structural system, the finite element method of analysis (FEA) can be used to determine the structural resistance.

Floors are limited to a maximum allowable uniform load of 40 psf (1915 Pa), and resistance to concentrated loads set forth in Table 16-A of the UBC is outside the scope of this report.

The minimum structural design criteria for SABS™ structures must be in compliance with the UBC. Wind resistance must be limited to 130 mph (57 m/s) basic wind speeds. The seismic coefficients, factors, and height limits must not exceed the following values:

R: 4.5

Ω_p : 3.5

The permitted Seismic Zones are 1, 2, 3, and 4. The building height is limited to a maximum of 40 feet (12 192 mm).

The following parameters must be the controlling factors in the design of SABS™ structures:

1. Flexural strength: Allowable flexural stresses must be no greater than one-third of the values determined in accordance with ASTM C 947 for the structural coating, and must not exceed 667 psi (4.596 MPa).
2. Compressive strength: Allowable compressive stresses must be no greater than one-third of the values determined in accordance with ASTM C 109 for the structural coating, and must not exceed 2,667 psi (18.367 MPa).
3. Modulus of elasticity for the structural coating used in design must be a maximum of 1,000,000 psi (6,895 MPa).
4. Modulus of elasticity of the EPS foam plastic used in design must be a maximum of 320 psi (2.205 MPa).
5. Strain: The design strain limit for SABS™ structural coating must be a maximum of 0.00067 in/in (mm/mm).
6. Deflection: The span/deflection ratio of all SABS™ structural components in flexure must be a maximum of 1/480 for combinations of dead and live loads ($D + L$). For other load combinations, limitations in the UBC must be observed.

Replace Section 4.3.1 with the following:

All structural coating applicators must be trained and certified by SIG. A list of all approved applicators must be made available at all SABS™ jobsite locations. The applicators must complete an annual update of their training, which includes retesting, and be retested to maintain their certification by SIG. SABS™ structures must be constructed

or installed in two primary classes: (1) custom and (2) prefabricated or high-volume production structures. Subassemblies of SABS™ components before erection may be prefabricated by an approved fabricator, or produced at the jobsite location. In either case, the structural design and construction quality control procedures must remain the same. In both classes, the thicknesses of the EPS foam plastic core and structural coating on both sides of the core must be predetermined by the structural analysis performed by a trained Strata International Group registered design professional.

The adhesive described in Section 3.2.3 must be used to connect EPS foam plastic sections to each other prior to the structural coating application. The structural coating provides the continuity for the entire SABS™ system.

The structural coating is spray-applied to EPS surfaces that are clean and free of loose particles and excess water.

Interior and exterior finishes and coverings may be installed in accordance with the applicable code.

Typical details are provided in Figure 3.

Replace Section 4.3.4 with the following:

Roof Assembly Classification: SABS™ roof elements with a minimum 8-inch-thick (203 mm) EPS component and a minimum $\frac{1}{4}$ -inch-thick (6.4 mm) structural coating on both faces comply as a Class A roof assembly when tested in accordance with UBC Standard 15-2.

Replace Section 4.4.1 with the following:

General: Special inspection in accordance with Section 1701 of the UBC must be provided. The special inspector's duties include:

- Verification of jobsite-prepared structural coating.
- Verification of size and location of structural elements.
- Verifying protection of construction during cold or hot weather.
- Verifying that surfaces are clean and dry prior to structural coating application.
- Verifying that structural coating application techniques and thicknesses are in compliance with this report and the construction document provisions.
- Verifying that specified curing temperature and techniques are maintained.
- Verifying preparation of structural coating test specimens.
- Verification of compliance with required inspection provisions of the construction documents and the approved submittals.

8.4 Conditions of Use:

See Section 5.0, except as follows:

Replace Section 5.3 with the following:

The structural design must comply with this report and the UBC and be approved by Strata International Group.

Replace Section 5.5 with the following:

Structures containing SABS™ are limited to Type V-N construction.

8.5 Evidence Submitted:

See Section 6.0.

8.6 Identification: See Section 7.0.

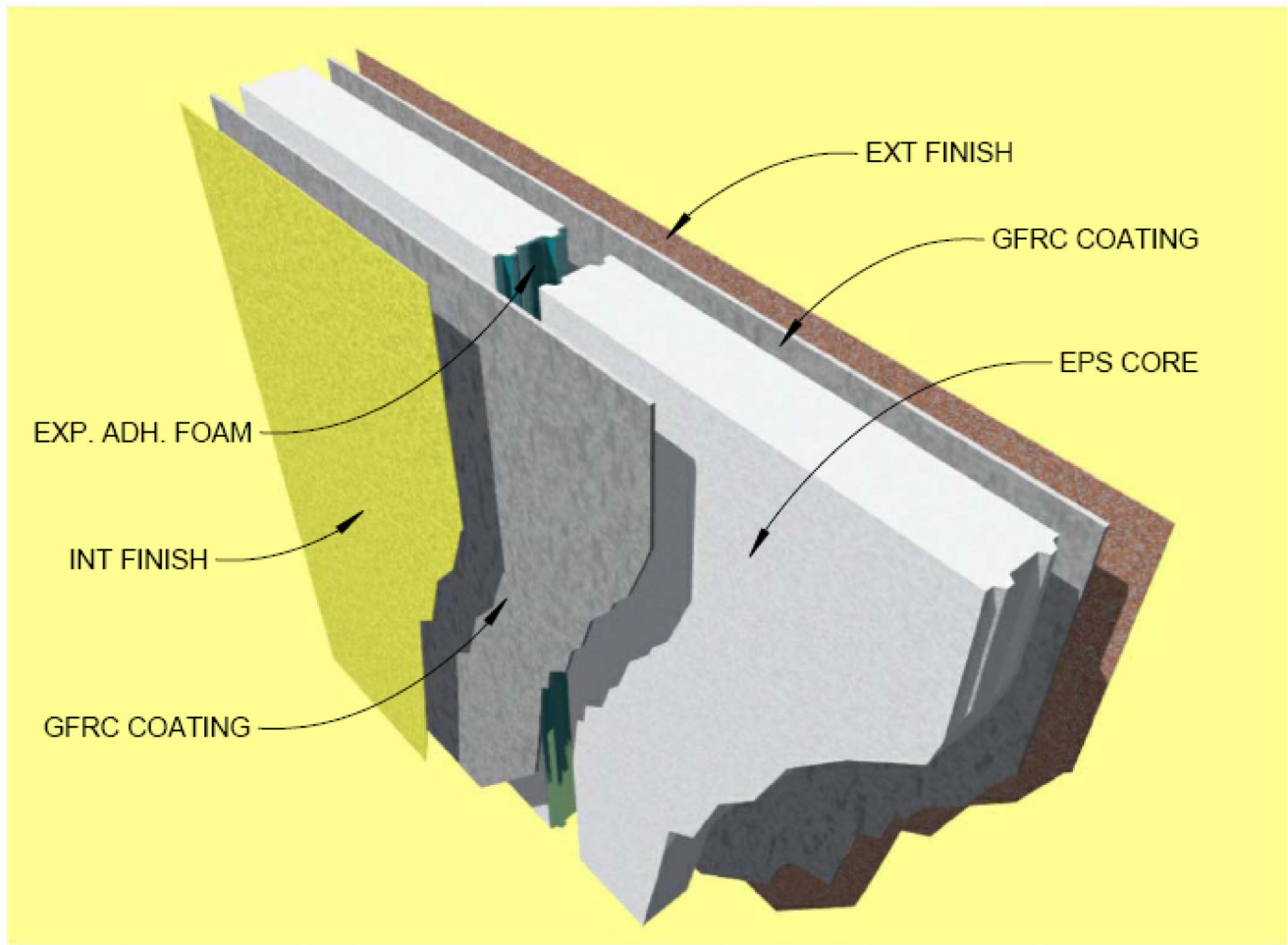

FIGURE 1—FLAT ELEMENTS

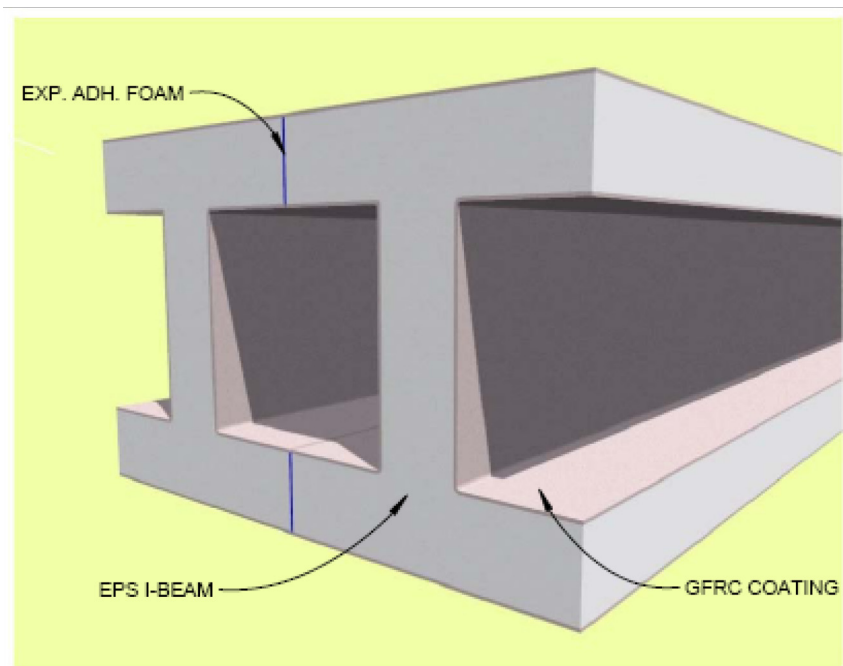

FIGURE 2—I-SHAPED ELEMENTS

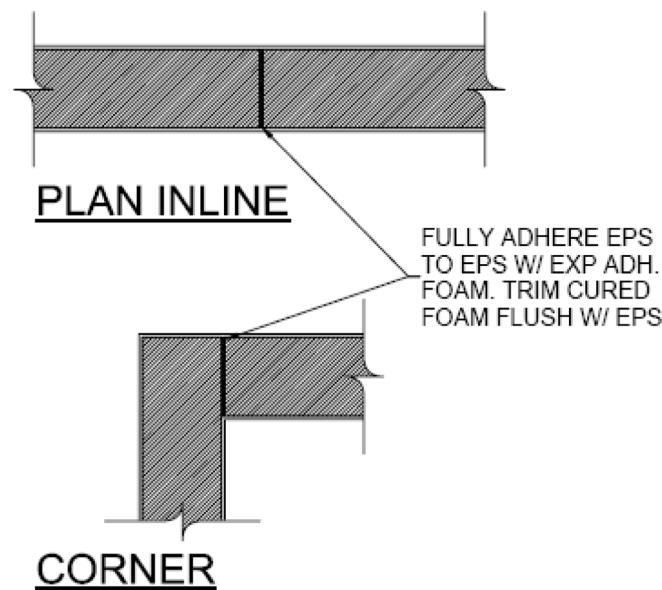
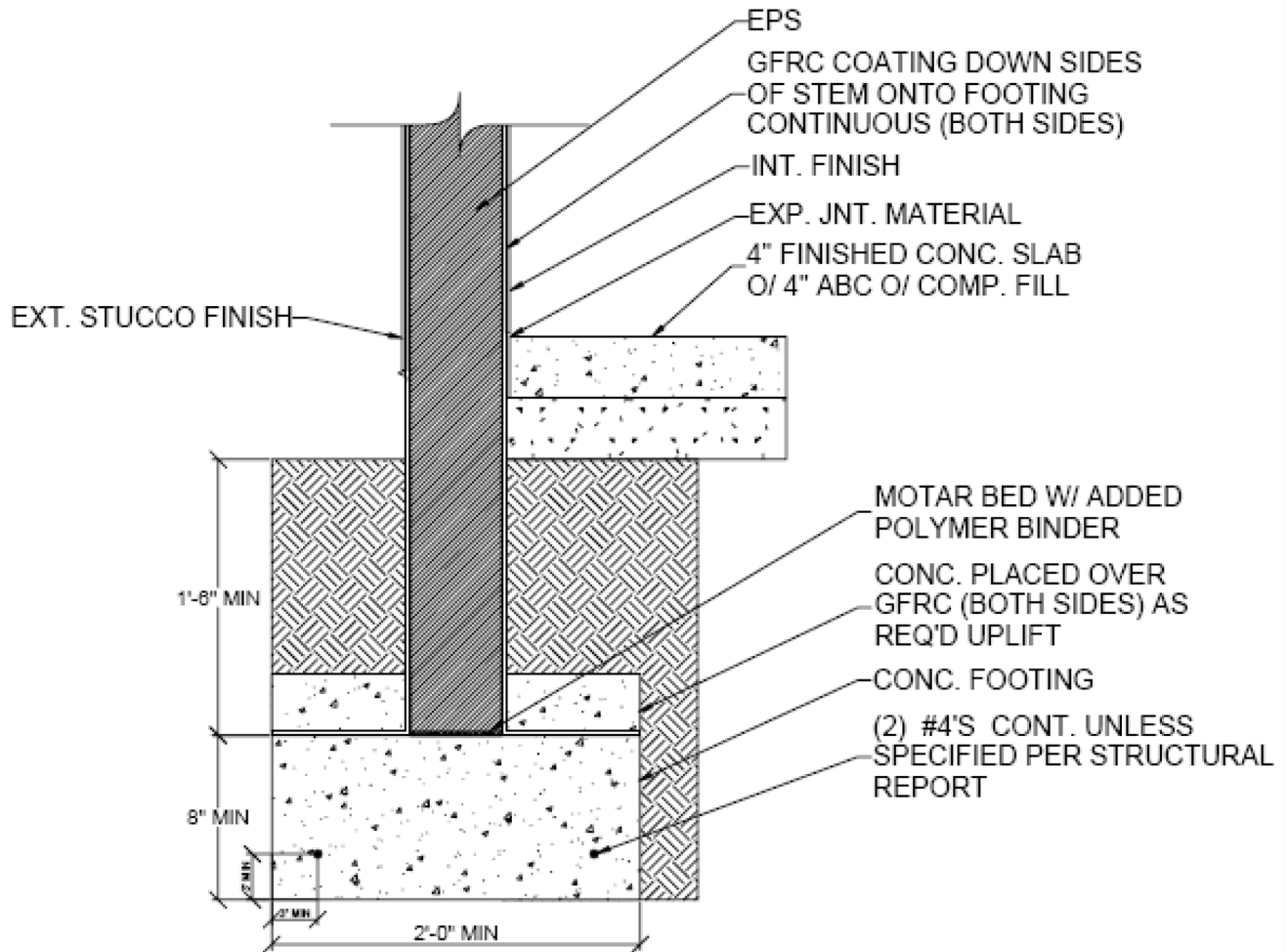

FIGURE 3—TYPICAL DETAILS